

Performance Measurement of Mini Steam Power Plant at Variable Flow Rate of Steam and Load

*Note: Sub-titles are not captured in Xplore and should not be used

Engr. Muhammad Amin
Mechanical Engineering
Dept.
Sarhad University of Science
and IT
Peshawar, Pakistan
amin153.me@gmail.com

Engr. Izaz Khan
Mechanical Engineering Dept.
Sarhad University of Science
and IT
Peshawar, Pakistan
ixaxkhan@gmail.com

Engr. Riaz Hussain
Mechanical Engineering Dept.
Sarhad University of Science
and IT
Peshawar, Pakistan
riaz.ali4@gmail.com

Engr. Junaid Ahmad
Mechanical Engineering Dept.
Sarhad University of Science
and IT
Peshawar, Pakistan
imjunaidak@gmail.com

ORCID: 0000-0002-4043-1513

For official correspondence
use [email](mailto:amin153.me@gmail.com) provided;
amin153.me@gmail.com

Abstract: Attaining optimal energy conversion in thermodynamics system, such as, in the Steam Turbine Power Plants (STPP), is a complex task due to the involvement of several factors. A study about the performance measurement and various parameters of a Mini Steam Turbine Power Plant along with their theoretical models has been carried out. This power plant is working on the Rankine cycle and using steam as working-fluid, produced in the boiler, the enthalpy of this steam (mostly superheated) is harnessed in the steam turbine, where it expands and produces output power, then from the turbine exit the steam is cooled back to condensate in a condenser, from where the resulting condensate is brought back to the feed water tank so that it could be supplied to boiler to keep the cycle repeating. This plant is facilitated by a monitoring section which consists of a control console along with pressure, temperature and rpm indicators. The expansion ratio, actual and isentropic power and corresponding efficiencies are the important parameters in the quantitative analysis in order to determine the performance of the steam turbine power plant. These parameters are evaluated at the turbine speed 1500 rpm approximately while the generator load was kept varying. An overall view of the Mini Steam Turbine Power Plant Rig is also stated. Improvements in the performance of power plants were also highlighted. For further improvements, this review highlighted some of the areas for further research and made recommendations for improvement in some aspects of the existing STPP.

Keywords: Steam power plant, Energy conversion, Exergy analysis, enthalpy, expansion ratio, isentropic power,

1. INTRODUCTION

Steam Turbine Power Plant schematic diagram is shown in *Fig. 1* and *Fig. 2* shows the detailed labeled diagram of the experimental test facility. A study is carried out at Steam Turbine Power Plant in Sarhad University of Science and IT, Peshawar, this power plant is working on the Rankine cycle and using steam as working fluid, produced in the boiler, the enthalpy of this steam (mostly superheated) is harnessed in the steam turbine, where it expands and produces output power, then from the turbine exit the steam is cooled back to condensate in a condenser, from where the resulting condensate is brought back to the feed water tank so that it could be supplied to boiler to keep the cycle repeating. As this plant is a power producing plant and the whole set-up of the plant is designed to get power output by means of Impulse turbine in this case. A steam turbine is a device which converts the thermal energy of steam (working fluid) into mechanical energy by using it to turn the blades of a rotor. high-temperature, high-pressure steam passes through a nozzle and is converted into a high-speed jet that is directed on the rotor blades that spins/rotates the shaft to which they are attached, thus producing mechanical power. Currently, the leading approach to the production of base-load electrical energy (electricity) globally is coal-fired (or conventional gas) power plants. However, this source of energy has fascinated much concern due to the problems related with its energy-generation step (process); among such problems is the associated greenhouse emissions and pollution/flu gas.

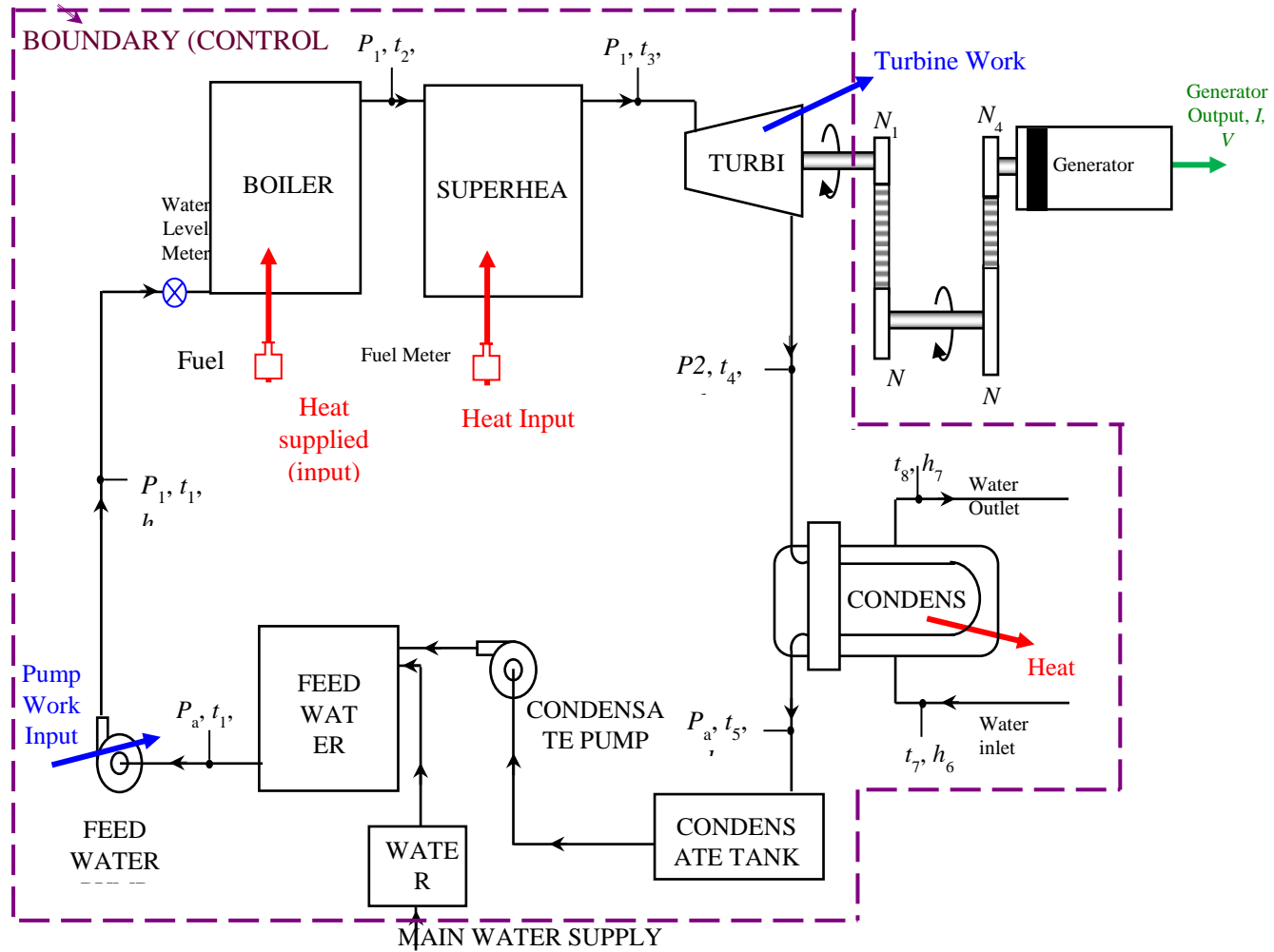

Fig. 1: Schematic Diagram of Steam Turbine-Generator Arrangement

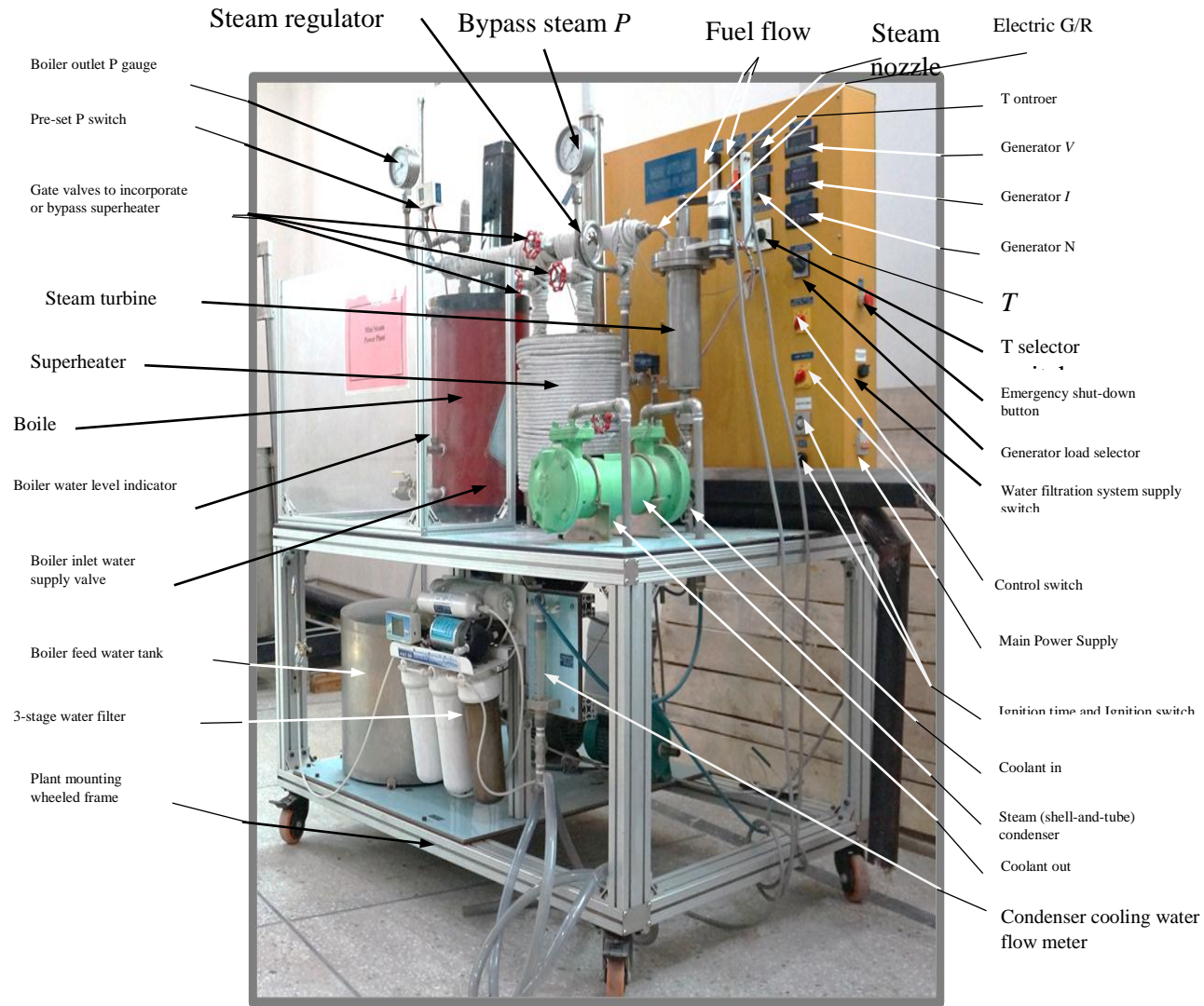

Fig. 2: Overall View of Steam Turbine Power Plant

2. PERFORMANCE MEASUREMENT OF STEAM TURBINE POWER PLANT

Performance measurement of a steam turbine power plant refers to the various performance parameters such as actual efficiency, isentropic efficiency, expansion ratio and generator load output. In forthcoming sections one performance parameter will be tested against other while keep varying mass-flow rate to evaluate its effect.

2.1 ISENTROPIC EFFICIENCY OF TURBINE VS. MASS FLOW RATE OF THE STEAM

Fig. 3 shows that the mass flow of steam (\dot{m}_s) and

used to convert pressure energy into kinetic energy in a pro rata, so increasing mass flow rate of the steam means increasing pressure at input of nozzle as result of high kinetic energy of the jet of steam increases, and consequently the isentropic efficiency. And it can be observed from the Fig. 3 that increasing mass flow rate of steam across the turbine results in an increase in expansion across the turbine consequently isentropic efficiency of the turbine increases. Of course, there is limitation of flow rate of steam beyond which efficiency decreases with further increase in mass flow rate of the steam in the authors' case. This decrease is because of the increase in generator's load. The explanation of the trend of the curves are similar to

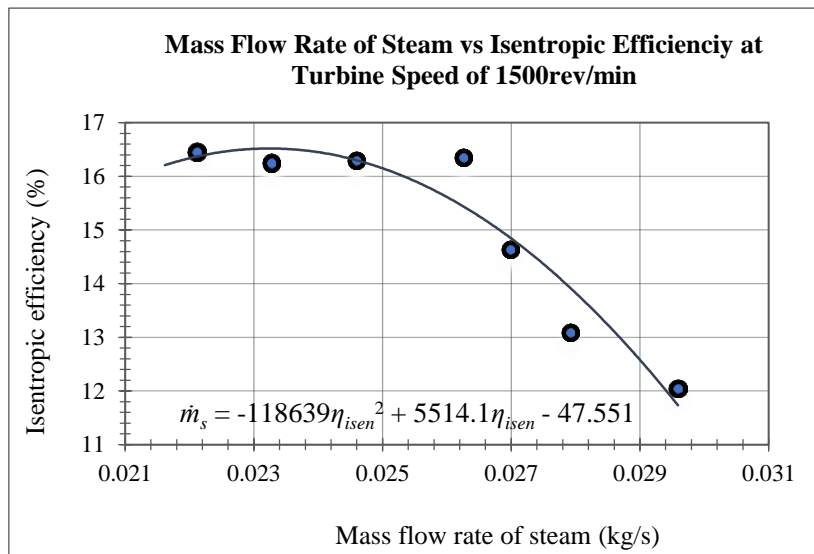

Fig. 3: Isentropic efficiency vs. mass flow rate.

isentropic efficiency ($\eta_{T,Isen}$) of the turbine has similar relation to that of the expansion ratio and isentropic efficiency provided the load is kept varying. High pressure steam from the boiler or superheater is expanded in turbine through a nozzle, since a nozzle is

what have been explained in the previous sub-section.

2.2 Isentropic Efficiency of Turbine vs. Expansion Ratio

The isentropic efficiency ($\eta_{T,Isen}$) of the turbine

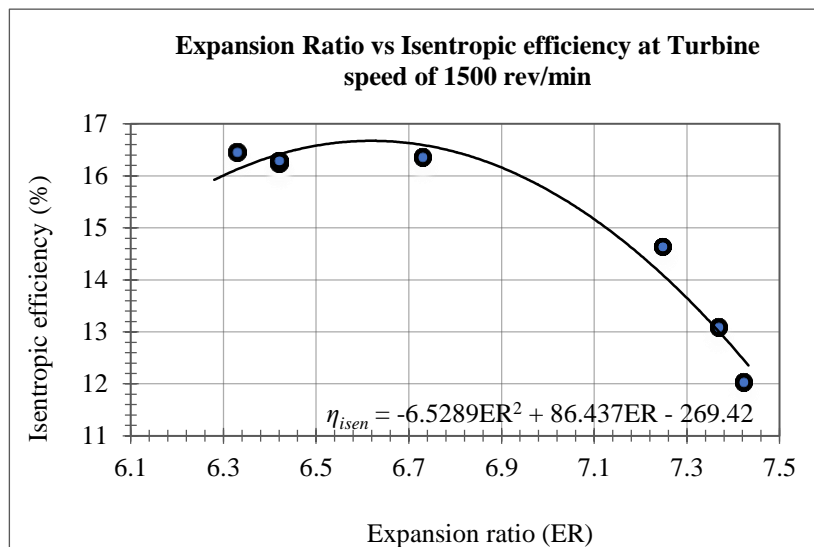

Fig. 4: Isentropic efficiency vs. expansion ratio

shows the ideal expansion of steam in turbine compare with actual expansion of steam in turbine. It is a tool or mean to provide a standard for a turbine and it shows the deviation of actual turbine work or power from its ideal. While pressure ratio across the turbine (also known as expansion ratio (ER)), since it is certain that high expansion of steam in a turbine from a high pressure to low pressure results in greater work output, consequently pressure ratio will be high, so expansion ratio is one of the parameters which expresses the performance of turbine. It can be clearly observed from the Fig. 2 that at each point isentropic efficiency of the turbine varies in non-linear manner with change in expansion ratio across the turbine.

Although the data interpretation and analyzed at one particular speed (of 1500 rev/min) due to the limitations of the rig as mentioned preciously the reader in the similar research field (be it a steam turbine or gas or hydraulic turbine) will definitely see similar underlying trend because this the kind of characteristics that is manifested during the performance testing a various turbomachine (esp. of rotodynamic impulse or reaction type). In addition, similar behavior will appear if this steam turbine is treated at different speeds. Higher the speed the upper will be the level of efficiency curve at those increasing speeds. No matter what the speed is, first it can be seen

the absolute flow angle (the angle which the steam exiting from the nozzle relative to the tangential direction of the turbine tip) and the blade angle of the turbine rotor. As a consequence, the steam guides smoothly in the blade channel, i.e., without shock and minimal friction between the flow and the blade channel surfaces as well as secondary losses between the pressure and suction sides of the blade. At other expansion rotors this may not be the case and the incidence angle, as explain above, and as a result all the benefits due to correct and desirable incidence angle may not be obtained. The efficiency will drop.

The reason for the plateau of the efficiency curve may be ascertained from the fact that the variation in the mass flow rate and hence expansion ratio is quite favorable and adaptable by the nozzle –rotor combination thus giving efficiency very close to the peak value of inside range of expansion ratio. This is the typical characteristic of any kind of high-speed rotodynamic machine (prime-mover or compressor). That can be found in the literature on the turbomachine or any text book on an advanced fluid mechanics including fluid power and fluid machinery, for instance, [1].

2.3 Actual Efficiency of Turbine vs Mass flow Rate

Unlike the isentropic efficiency, the actual efficiency of the entire steam turbine power plant is far less for

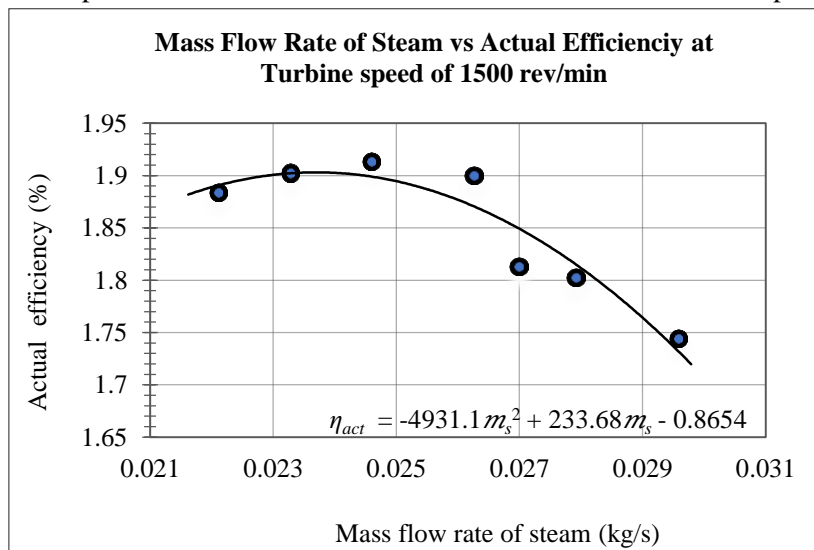

Fig. 5: Actual efficiency of the steam turbine vs. mass flow rate

for the graph shown Fig. 4. That efficiency has minimum value at lower expansion ratio, increases at to its peak value and then decreases drastically as the expansion ratio. Secondly the efficiency curve has flatter characteristics over a pretty wide range of expansion ratio. The rationale for these two characteristic behaviors is explained below.

The reason for the decrease in efficiency on either side of its peak value (16.6% In this case) may be attributed to the fact that there is only one point where there is a perfect matching (at some incidence angle) between

the same temperature and working pressure. Actual efficiency of turbine refers to the ratio of the work output to the heat supplied to the working fluid (steam). Relationship between mass flow rate of steam and efficiency are neither direct nor inverse, i.e., it will not be correct to say that efficiency of steam turbine increases with increases in mass flow rate of steam, also that efficiency of turbine decreases with increase in mass flow rate [2]. Simply there two sections of the graph of the mass flow rate and efficiency, first increasing portion and second decreasing portion. Let

starts from the very beginning, an increase in mass flow rate of steam results in increasing efficiency of the turbine, a point will come at which efficiency of the turbine will not be increased with increase in mass flow rate and soon after increasing the mass flow rate will result in gradually decrease in the efficiency of the turbine. The Fig. 5 expresses the relationship of the steam mass flow rate and turbine efficiency graphically. It should be born in mind that the all kinds of losses, such as combustion, in boiler, superheater, fluid friction, mechanical [3], etc., implicit in the definition of the actual (or overall) efficiency of the entire steam turbine power plant.

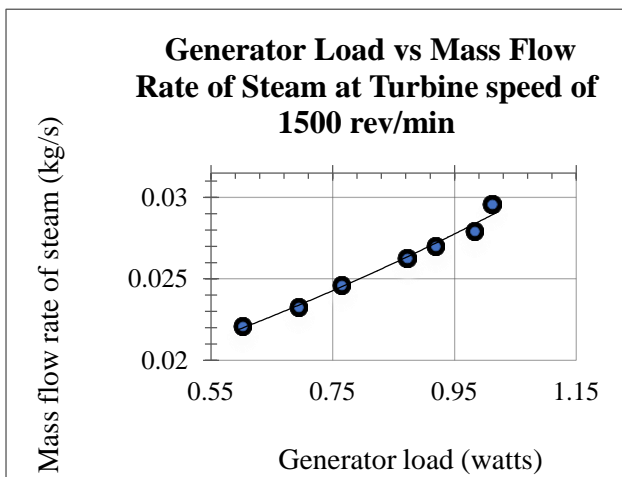

Fig. 6: Generator load vs. mass flow rate of steam

2.4 Generator Load Vs. Mass Flow Rate of Steam at a constant Turbine Speed

Since the main purpose of a power plant is to produce power (mechanical power) and later converts into electrical power in an electric generator. This process involves input to turbine (i.e., steam), output of turbine (shaft power) that is readily provided to generator. For instance, consider a load carrying vehicle, if load is increased on the vehicle as result its speed will decrease, to maintain a constant speed the driver has to increase the fuel by depressing accelerator more. Similarly, Fig. 6 illustrates the relationship of varying generator load with mass flow rate of steam. It can be clearly observed from the figure that increase in the generator load will require an increase in mass flow rate of the steam to maintain a constant speed of the turbine. The gradual increase in the generators' load against the mass flow rate of the steam is depicted in figure shown below.

2.5 Relationship between Mass Flow Rate of steam and Expansion Ratio across the Turbine

Mass flow of steam is in direct relation with expansion ratio across the turbine. High pressure steam from the boiler and/or superheater is expanded in turbine through a nozzle, which converts pressure energy into kinetic energy in a direct relation, so increasing the mass flow rate of the steam results in increasing pressure at input of nozzle as result high kinetic energy of the jet of steam increases. Consequently, expansion ratio increases. It can be observed from the Fig. 7 that increasing mass flow rate of steam across the turbine results in an increase in expansion across the turbine consequently isentropic efficiency of the turbine increases. Of course, there is limitation of flow rate of steam beyond which efficiency decreases with further increase in mass flow rate of the steam in the authors' case. The characteristic behavior of the turbine isentropic efficiency in both the cases, when plotted against them, will be similar due to the logical reasoning put forward in this report.

3. Improvement in the performance of Steam Power plants

As we know that the population of the world grows at a staggering rate, so there is an increasing need of alternative sustainable resources that do not affect the environment. The best solutions to this problem are to improve efficiency of power plants that energize the homes and industries; in addition, performance of STPP can also be improved by the following,

- Improving the quality of fuel input / heat source.
- Improving the quality of combustion/ heat generation.
- Improving the quality of heat exchange throughout the plant cycle.
- Operating individual units, auxiliaries, and ancillaries efficiently.

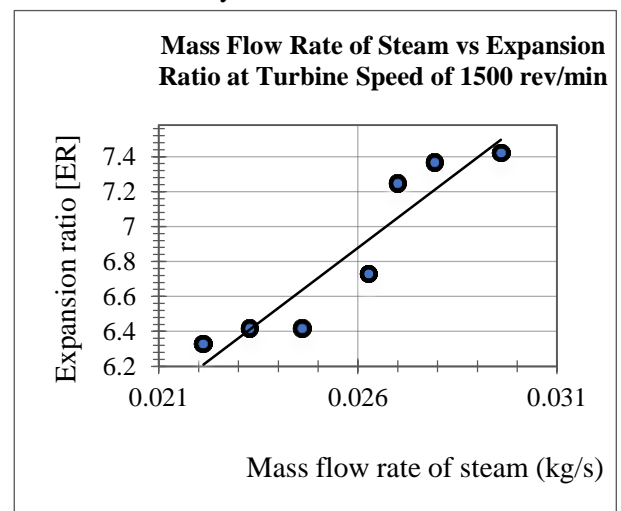

Fig. 7: Mass flow rate of steam and expansion ratio

- Operating the plant safely and correctly, according to procedures, at design & optimum levels--including in emergency situations.
- Maintaining all plant units effectively, minimizing defects and maximizing plant availability.
- Recycling and re-using excess generated heat.
- Keeping all plant cycles (e.g., steam/water), in a tightly closed loop, minimizing losses.
- Minimizing Heat Loss throughout the plant cycle.

4. Closing remarks

The analysis is carried out in this paper to be able to help understand the performance of STPP and identify and design possible efficiency improvements. In addition, exergy methods are useful in assessing which enhancements are worthwhile and should be used laterally with other pertinent information to guide efficiency enhancement efforts for STPPs. Of course, measures to improve efficiency should be weighed against factors discussed and implemented only where appropriate. The data in this study is ever important, as a method of electricity production continue to be

developed, for instance a combined power-producing system including a Rankine cycle and an integrated gasification power producing plant in the sawmill industry [4], and a combined solar trough and tower aided coal-fired power generation system.

ACKNOWLEDGMENT

The authors are extremely grateful for support they got from Engr. Dr. Prof. Imtiaz Hakeem throughout this study.

REFERENCES

- [1] A.N. Kolmogorov "The local structure of turbulence in incompressible viscous fluid for very large Reynolds numbers" *Cr Acad. Sci. URSS*, 30 (1941), pp. 301-305
- [2] M.A. Rosen, D.S. Scott, "Entropy production and exergy destruction: Part II"—illustrative technologies *Int J Hydrogen Energy*, 28 (2003), pp. 1315-1323
- [3] Khurmi R. S. and Gupta J. K. (2008). "A Text Book of Thermal Engineering", S.I. Units, 15th Ed., S. Chand and Company Ltd., Ram Nagar, New Delhi. ISBN: 81-219-2573-8. pp 19-22.
- [4] Hakeem I, (1995). "Steady and Unsteady performance of mixed-flow turbine for automotive turbocharger," PhD thesis, Imperial College of Science, Technology and Medicine, University of London.